

**NOTES:**

- 1- ALL CONCRETE TO BE 4500 PSI, AIR ENTRAINED 4% TO 7%.
- 2- FOR ALL CONCRETE SIDEWALKS: TRANSVERSE EXPANSION JOINTS, 1/2" WIDE, SHALL BE PROVIDED AT INTERVALS OF NOT MORE THAN 20' AND FILLED WITH PREFORMED BITUMINOUS CELLULAR TYPE JOINT FILLER. LOGITUDINAL JOINTS, 1/2" WIDE, SHALL BE PROVIDED BETWEEN CURBS AND ABUTTING SIDEWALKS, AND SHALL BE FILLED WITH PREFORMED BITUMINOUS TYPE JOINT FILLER.
- 3- SIDEWALK WIDTH SHALL BE 4'-0" MINIMUM UNLESS NOTED ON THE APPROVED PLANS.
- 4- TYPE OF SEEDING SHALL MEET FREEHOLD SOIL CONSERVATION DISTRICT REQUIREMENTS.
- 5- AT DRIVEWAY OPENINGS, CONCRETE SIDEWALK AND DRIVEWAY APRON ARE TO BE 6" THICK WITH 6" x 6" STEEL WIRE FABRIC PLACED AT MID DEPTH.
- 6- CONCRETE SHALL NOT BE POURED ON FROZEN SOIL OR WHEN STANDING WATER IS PRESENT IN THE FORMS. TEMPERATURES MUST BE 32° FAHRENHEIT AND RISING FOR 24 HOURS AFTER THE CONCRETE IS POURED.
- 7- FORM INSPECTION AND FINAL POUR INSPECTION MUST BE SCHEDULED 24 HOURS PRIOR TO EACH EVENT BY CONTRACTOR.

**FOR CURBS ONLY:**

- 1- EXPANSION JOINTS IN CONCRETE CURB SHALL BE PROVIDED AT APPROXIMATELY EQUAL DISTANCES OF NOT MORE THAN 10' BETWEEN JOINTS AND SHALL BE FILLED WITH PREFORMED EXPANSION JOINT FILLER, 1/2" THICK AND FLUSH WITH TOP AND FACE.
- 2- CURB SHALL BE INSTALLED ON 5" THICK DENSE GRADED AGGREGATE BEDDING.
- 3- GRANITE BLOCK CURB TO HAVE CONVEX TOOLED JOINTS FILLED WITH 1:2 MORTAR, MAX 3/4" WIDE.

**WOODBRIIDGE TOWNSHIP**

1 MAIN STREET

WOODBRIIDGE, N. J. 07095

TELE: (732) 634-4500 FAX: (732) 602-6048

DRAWN BY: M.J.F. DATE: 3/6/07

**STANDARD CONSTRUCTION DETAIL  
NOTES FOR  
CONCRETE SIDEWALK, CURB AND  
DRIVEWAY APRONS**

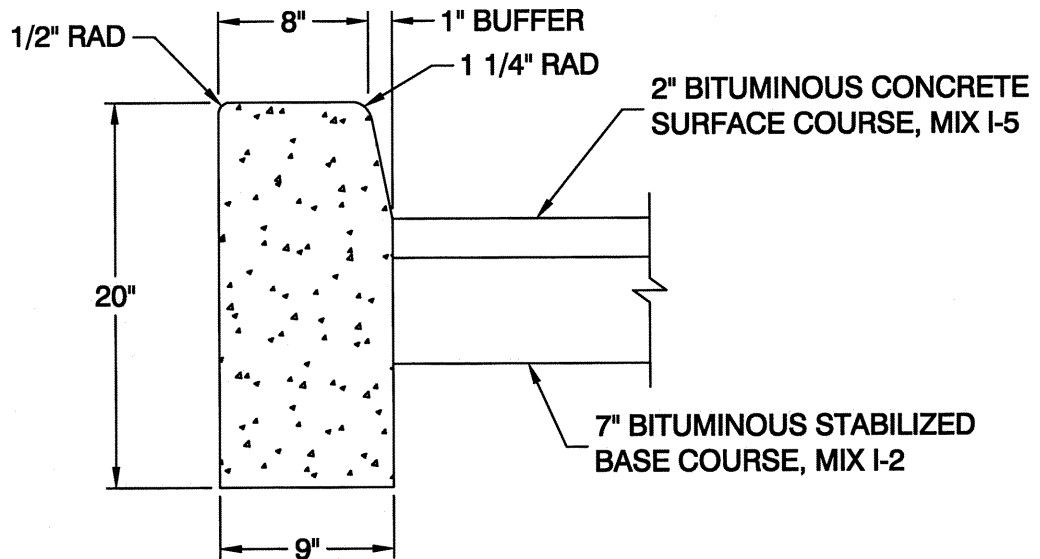

**TYP 9" x 20" CURB DETAIL**

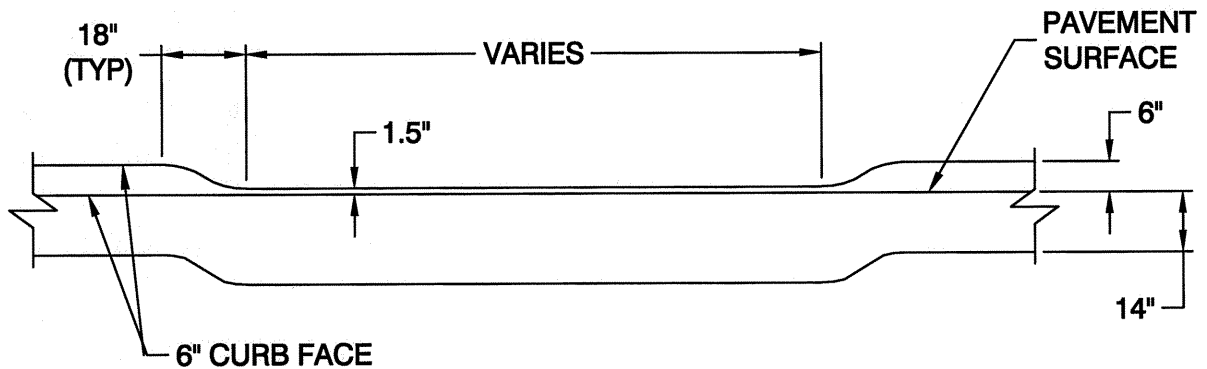

**DEPRESSED CURB AT DRIVE APRON**

**NOTE:**

FOR NOTES SEE STANDARD CONSTRUCTION DETAIL NOTES SHEET.

**WOODBRIAGE TOWNSHIP**

1 MAIN STREET

WOODBRIAGE, N. J. 07095

TELE: (732) 634-4500 FAX: (732) 602-6048

DRAWN BY: M.J.F. DATE: 3/6/07

**STANDARD CONSTRUCTION DETAIL  
FOR  
CURB DETAIL**

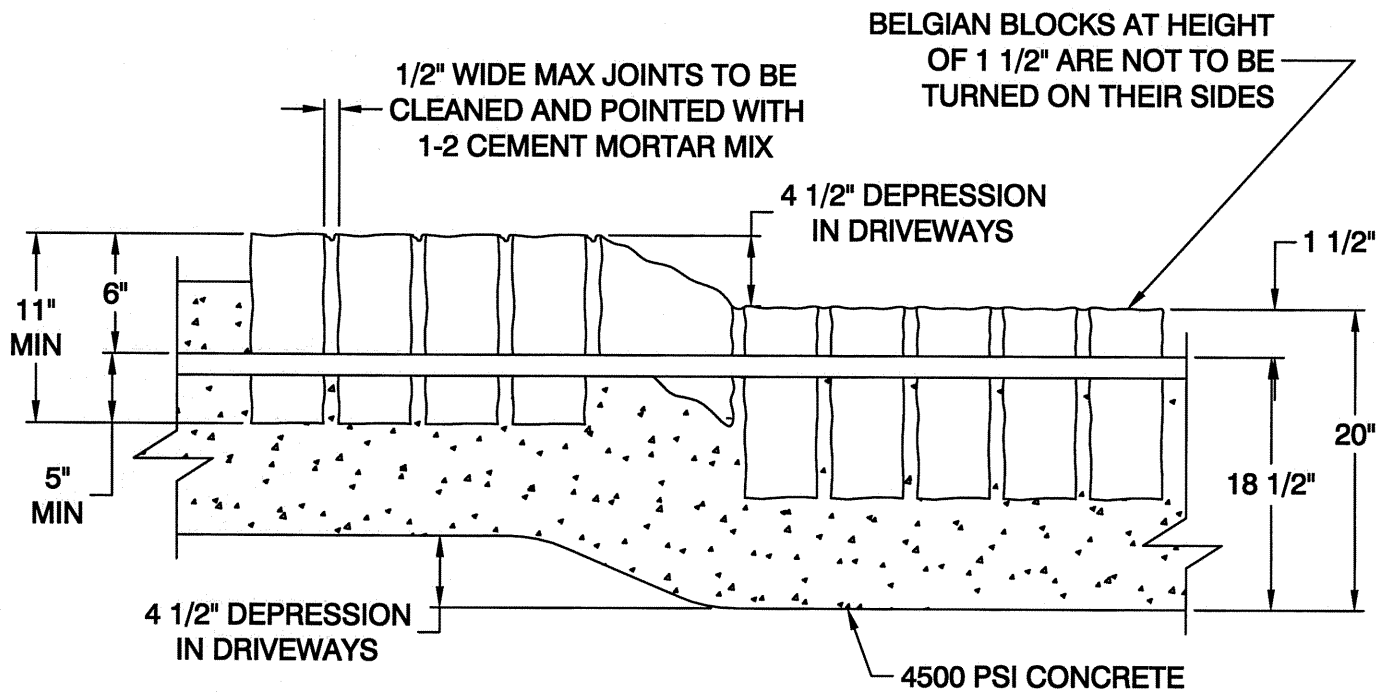
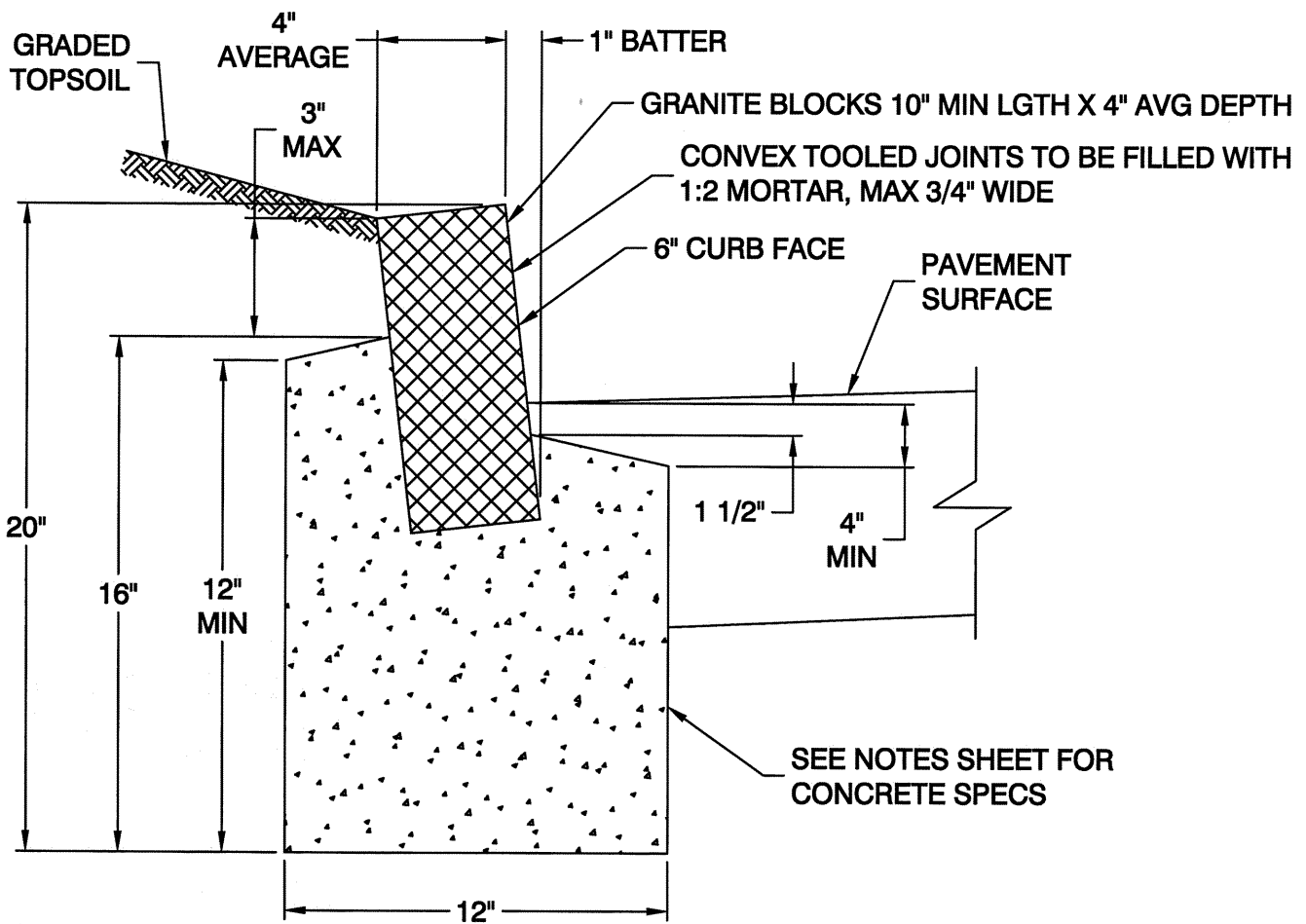

**WOODBRIAGE TOWNSHIP**

1 MAIN STREET

WOODBRIAGE, N. J. 07095

TELE: (732) 634-4500 FAX: (732) 602-6048

DRAWN BY: M.J.F. DATE: 3/6/07

**STANDARD CONSTRUCTION DETAIL  
FOR  
GRANITE BELGIAN BLOCK CURB**

**ALL WORK TO CONFORM TO WOODBRIDGE  
TOWNSHIP STANDARDS AND SPECIFICATIONS**

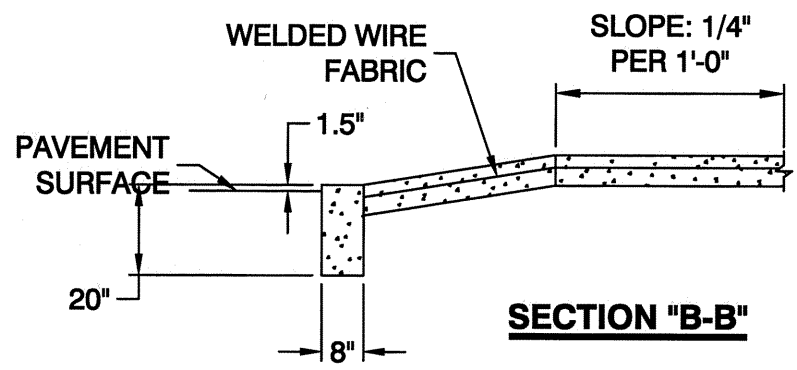
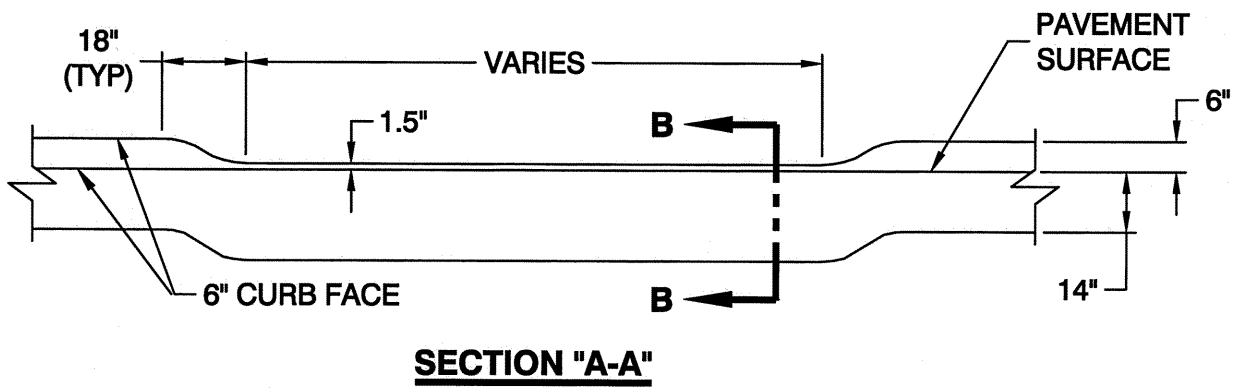
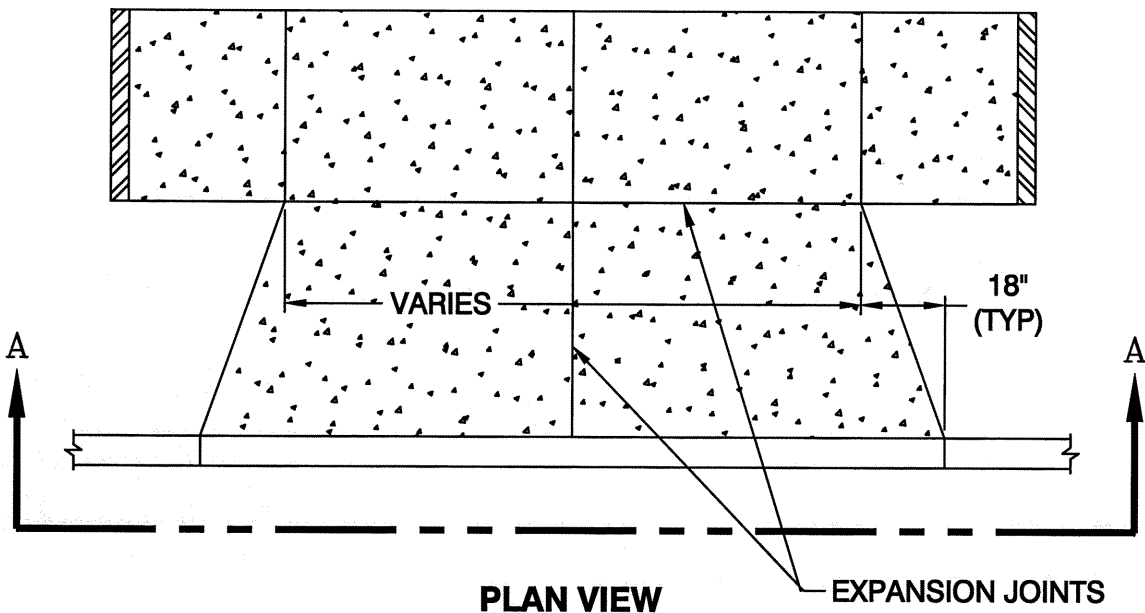

**NOTE:**  
FOR NOTES SEE STANDARD CONSTRUCTION DETAIL NOTES SHEET.

**WOODBRIDGE TOWNSHIP**  
1 MAIN STREET  
WOODBRIDGE, N. J. 07095  
TELE: (732) 634-4500 FAX: (732) 602-6048  
DRAWN BY: M.J.F. DATE: 3/6/07

**STANDARD CONSTRUCTION DETAIL  
FOR  
DEPRESSED CURB & DRIVE APRON**

**ALL WORK TO CONFORM TO WOODBRIDGE  
TOWNSHIP STANDARDS AND SPECIFICATIONS**

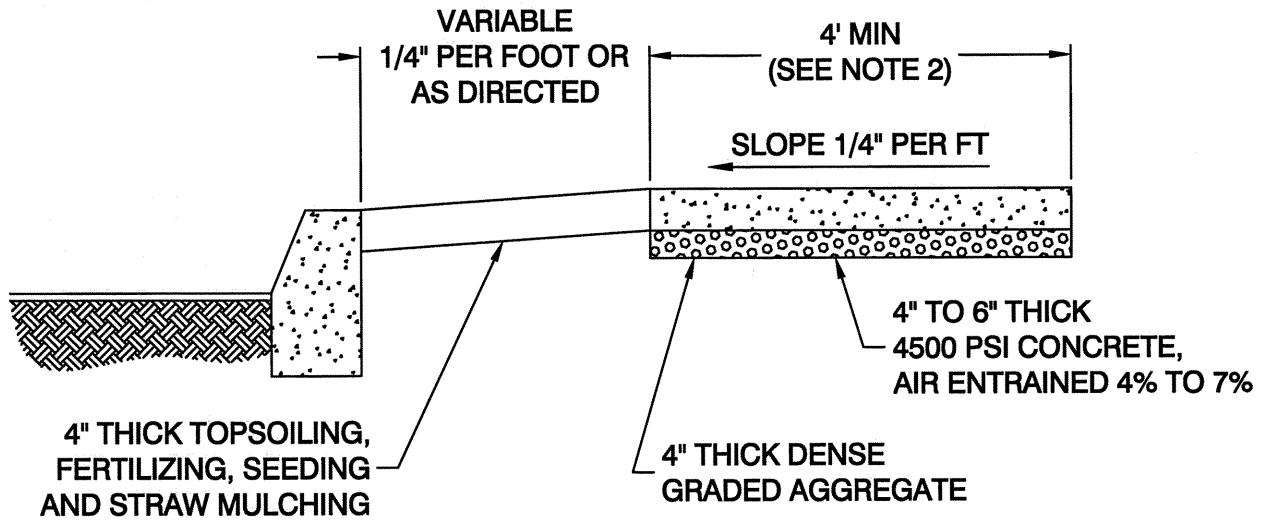
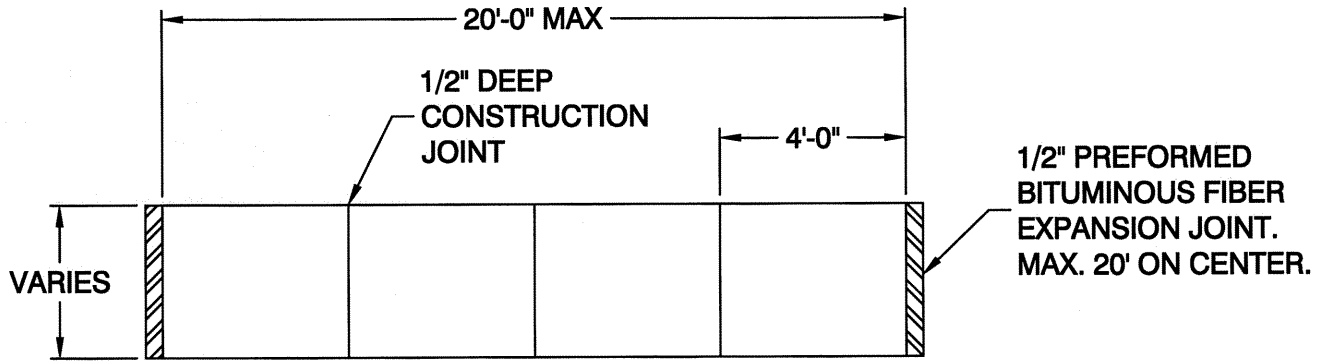

**NOTE:**

FOR NOTES SEE: STANDARD CONSTRUCTION DETAIL NOTES SHEET.

**WOODBRIDGE TOWNSHIP**

1 MAIN STREET

WOODBRIDGE, N. J. 07095

TELE: (732) 634-4500 FAX: (732) 602-6048

DRAWN BY: M.J.F. DATE: 3/6/07

**STANDARD CONSTRUCTION DETAIL  
FOR  
REINFORCED CONCRETE SIDEWALK**

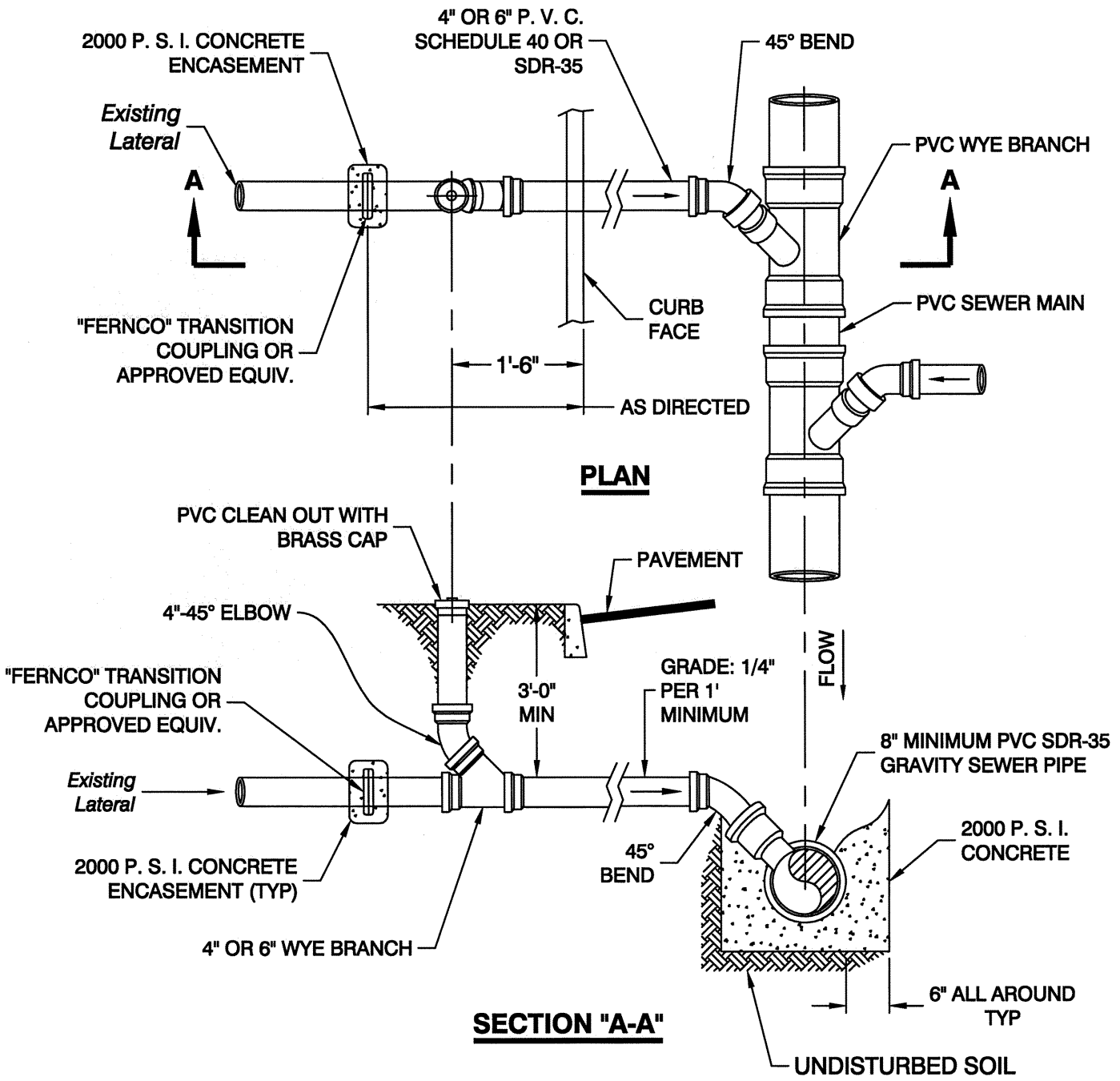

**PVC SANITARY SEWER  
LATERAL AND CLEANOUT**

**WOODBRIIDGE TOWNSHIP**

1 MAIN STREET

WOODBRIIDGE, N. J. 07095

TELE: (732) 634-4500 FAX: (732) 602-6048

DRAWN BY: M.J.F. DATE: 3/6/07

**STANDARD CONSTRUCTION DETAIL FOR  
PVC SANITARY SEWER LATERAL AND  
CLEANOUT**

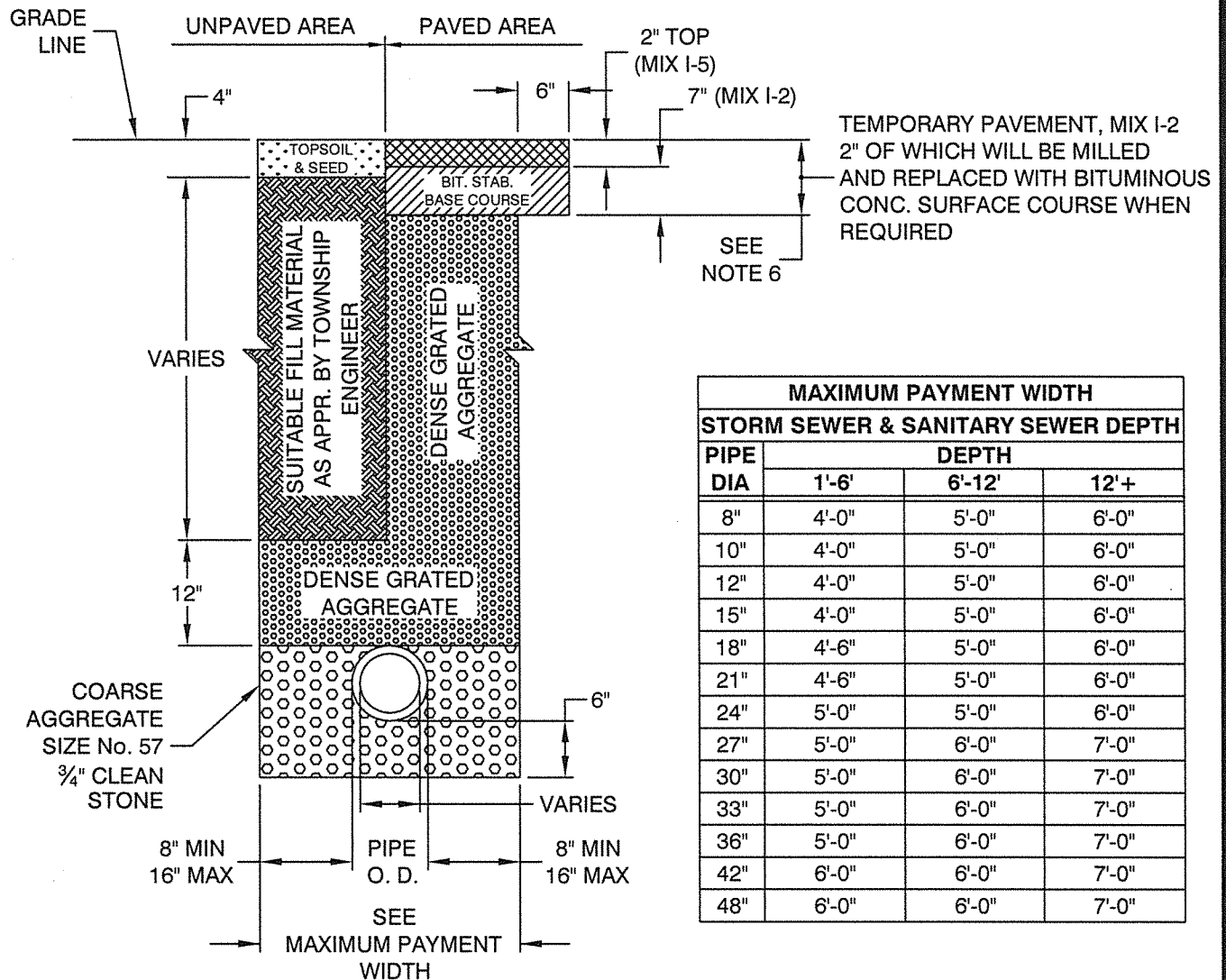

MAXIMUM PAYMENT WIDTH			
PIPE DIA	STORM SEWER & SANITARY SEWER DEPTH		
	DEPTH		
	1'-6"	6'-12"	12'+
8"	4'-0"	5'-0"	6'-0"
10"	4'-0"	5'-0"	6'-0"
12"	4'-0"	5'-0"	6'-0"
15"	4'-0"	5'-0"	6'-0"
18"	4'-6"	5'-0"	6'-0"
21"	4'-6"	5'-0"	6'-0"
24"	5'-0"	5'-0"	6'-0"
27"	5'-0"	6'-0"	7'-0"
30"	5'-0"	6'-0"	7'-0"
33"	5'-0"	6'-0"	7'-0"
36"	5'-0"	6'-0"	7'-0"
42"	6'-0"	6'-0"	7'-0"
48"	6'-0"	6'-0"	7'-0"

**NOTES:**

- 1- CONTRACTOR IS RESPONSIBLE FOR ULTIMATELY PROVIDING PERMANENT PAVEMENT (UNLESS OTHERWISE NOTED IN SUPPLEMENTARY SPECIFICATIONS).
- 2- SEE SPECIFICATIONS FOR MILLING AND PAVEMENT SURFACE COURSE REQUIREMENTS.
- 3- SEE SANITARY DETAILS FOR PVC PIPE BEDDING.
- 4- SHEETING TO BE PROVIDED WHERE NECESSARY (SEE SPEC. SECTION 513). IF SHEETING IS USED, THE CONTRACTOR SHALL BE PAID FOR ACTUAL TRENCH WIDTH'S NOT EXCEEDING THOSE FOR 1'-6' DEPTH.
- 5- CONTRACTOR SHALL BE PAID FOR ACTUAL WIDTH NOT EXCEEDING THE MAXIMUM WIDTH INDICATED IN THE MAXIMUM PAYMENT CHART.
- 6- BASE COURSE SHALL BE INCREASED TO 9" ON HEAVY TRAFFIC STREETS IDENTIFIED IN ORDINANCE No. 05-37 DATED 6/8/2005.

ALL WORK TO CONFORM TO WOODBRIDGE TOWNSHIP STANDARDS AND SPECIFICATIONS

N. T. S.

**TOWNSHIP of WOODBRIDGE**  
 DIVISION OF ENGINEERING  
**DUCTILE IRON, PVC and**  
**CONCRETE TRENCH DETAIL**

REVISED MARCH 2012